

Advanced Strap Dispensing Solutions for all Industries

Model CD12



Features

- Standard or Jumbo Coil Capacity
- Large Capacity Tower
- Quick Take-Up Response
- Self Contained Controls for Independent Operation or Systems Integration
- “Out of Strap” Switch
- Minimal Space Requirements
- Linear Bearing Carriage Travel

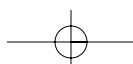

Model CD12 Strap Dispenser

Model CD12

The Samuel CD12 Strap Dispenser is designed to meet the demands of today's high performance polyester unitizing machines. The versatile drum will hold multiple coil sizes as a standard feature. With an optional easy loading jib and c-hook attachment, the CD12 will handle Jumbo Coils up to 160 lbs. A high torque 3 phase gear motor and V.T. drive ensure smooth drum rotation and high performance strap delivery.

Construction

The CD12 features rugged structural steel tower construction which will withstand the demands of any plant environment. High capacity linear bearings on the tower take up carriage ensure that strap will be delivered at whatever speed or tension your system requires. UL and CSA approved electronics can be combined with your system controls for maximum safety for plant workers.

General Specifications

Unit Height	91" (2310mm)
Unit Width	30" (760mm)
Unit Length	50.1/2" (1280mm)

Power Requirements

Voltage	110 volts single phase
Current	10 Amps

Options

Easy loading jib and c-hook attachment

Coil Data

Max Coil Weight	160lbs (72 kg)
Max Coil O.D.	32" (813mm)
Coil I.D.	16" (406mm) min 24" (610mm) max
Coil Face Width	6" (152mm)
	7 1/2" (190mm)

Feed Rate & Accumulation

Max Drum Speed at 60HZ	63 RPM
Recommended jog speed at 20HZ	21 RPM
Feed Rate at 32" O.D.	528 FPM (161 M/min)
Feed Rate at 16" I.D.	264 FPM (80 M/min)
Max Tower Capacity	37' 8" (11.5m)

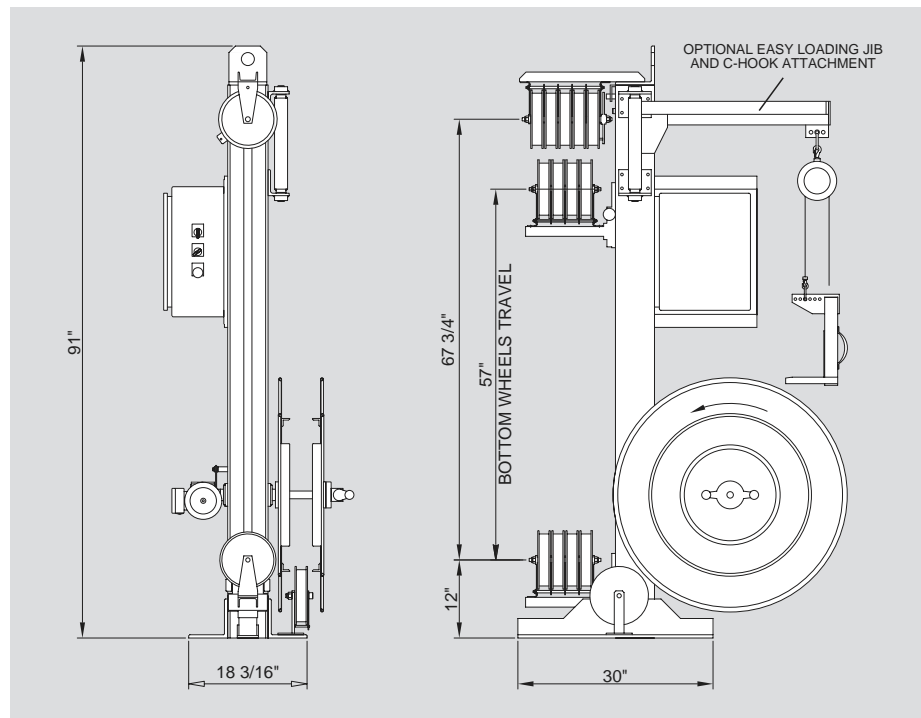
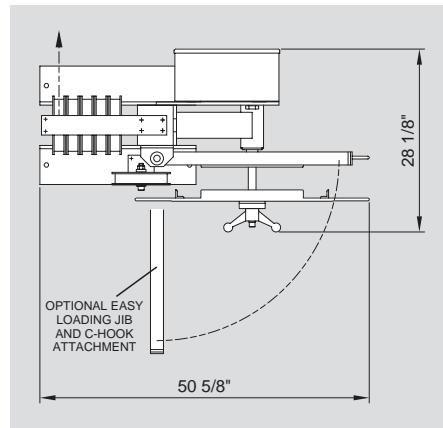

Samuel Strapping Systems

U.S.A.
1-800-323-4424
Canada
1-800-607-8727

www.samuelstrapping.com