

# Can/Bottle Unitizing Systems

---

## **Model SBC-932**



### **Features**

- Performance
- Reliability
- Economical
- Low Maintenance

# Model SBC-932 Automatic Side Seal Strapping Machine

## Standard Features

The Samuel SBC-932 Automatic Strapping Machines are ideal for securing bulk loads of PET bottles, glass bottles, aluminum, steel and composite cans. The 932 utilizes a heat seal method to weld the strap together providing reliable, uniform and high strength seal joints. The heavy duty heat knife has a life of 200,000 plus cycles. The STR-14 strapping head automatically indexes up to 14" to the load side to assure tight, secure and accurate strap replacement. All functions are PLC controlled. The STR-14 is designed to be maintenance friendly and a low cost head to operate.

## Specifications

Electrical:	230/460, 3hp, 60hz	Free Standing 500 lbs. Load Stabilizer (PET Bottles)
Air:	80 psi	
Speed:	Feed and Take up 7-15 FPS	Free Standing 1,200 lbs. Load Compression (Cans)
Sealing Method:	Heat Weld	
Machine Weight:	1,800 lbs.	Free Standing 4,000 lbs. Load Compression System (Glassware)
Strapping:	Polypropylene or Polyester	
Strap Size:	3/8" (9 mm) - 3/4" (19 mm)	Strap Underfeed
Tension:	up to 500 lbs. (adjustable)	Multi-Strand or Roller Conveyor with or without Turntable

## Options

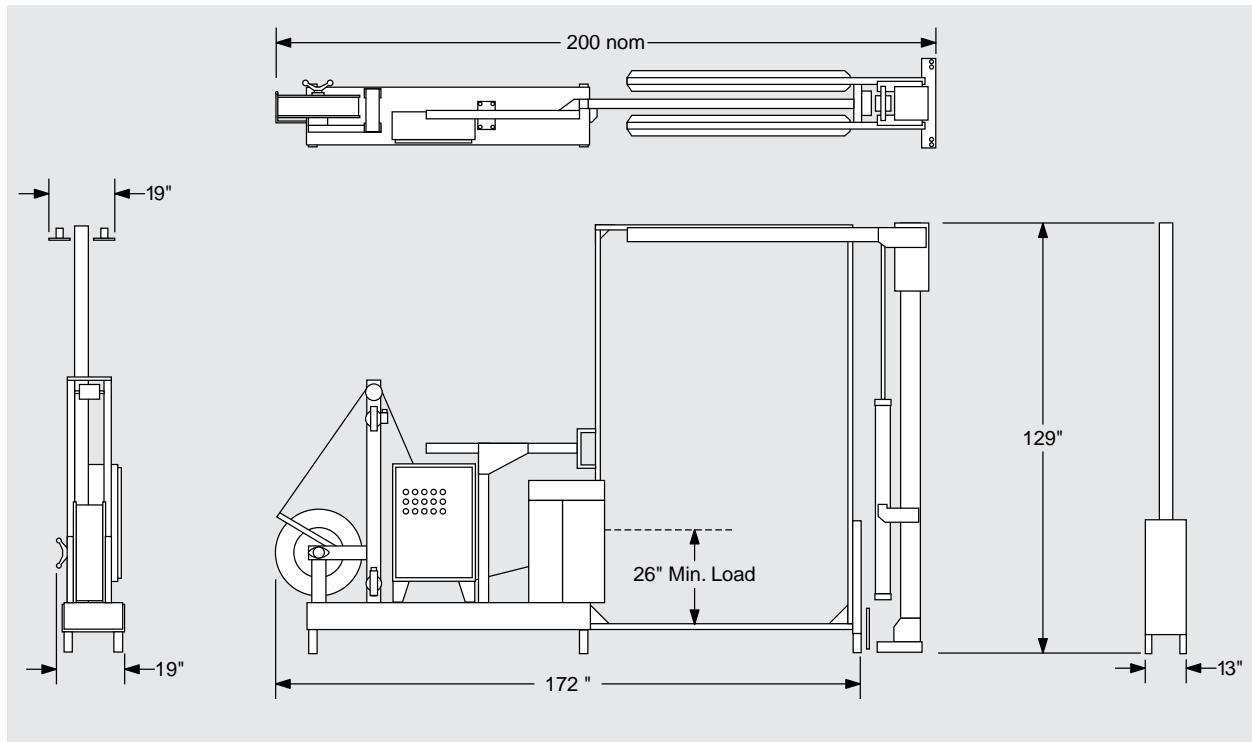

## Samuel Strapping Systems

An Innovative Company  
with Innovative Solutions

In Canada call Toronto  
Tel: (905) 279-9580  
Fax: (905) 279-8016

In the U.S.A. call Illinois  
Tel: (630) 783-8900  
Fax: (630) 783-8901

For other locations in Canada  
call 1-800-607-8727

For other locations in the U.S.A.  
call 1-800-323-4424