



Advanced Strapping Solutions for the Corrugated Industry

Model SCU8



Features

- Reliable High Speed Strapping Heads
- Seals Both Polyester and Polypropylene Straps
- Advanced Heads Provide High Strap Tension
- User-Friendly Programmable Controllers
- Rugged Steel Construction
- Pre-wired 3rd Head Standard
- Low Platen Height for Ease of Service

Model SCU8 Main Line Unitizer

SCU8 Unitizer

Designed for the demands of the corrugated industry, the SCU8 produces securely unitized corrugated loads to meet your specific requirements. High performance heads and components keep your efficiency high and your packaging costs low.

Construction

The SCU8's framework is built from heavy steel to withstand a lifetime of use in demanding plant environments. The heavy steel platen and reinforced under conveyor supports allow high compression ratios on your corrugated loads.

Compression System

The versatile hydraulic compression system allows you to choose the compression that suits your particular packaging requirements. Our standard model offers compression up to 8000 lbs, with higher levels available as an option.

VK20 Strapping Head

The VK20's high operating speeds allow high strap throughput while the heavy duty heater maintains excellent joint efficiency and strap tension. It offers you the flexibility to use polyester or polypropylene strap in 1/2" to 5/8" gauges with only minor on-site adjustments. The VK20's all-electric design has less moving parts which provides for greater reliability and reduced maintenance costs.

Controls

The user-friendly programmable controllers are state-of-the-art and provide an O.E.M. system suitable for interfacing with any standard conveyor equipment.

Specifications

Max. Load Height	74" or 88"
Min. Load Height (with optional Pallet Void feeders the minimum height is 18")	10" or 24"
Max. Load Width	102"
Min. Load Width	24"
Through Clearance	102"
Compression Range	1,000 to 8,000 lbs. (Higher levels optional)
Compression Sys.	Hydraulic
Maximum Diagonal Package Dimension	102"
Internal Powered Roller Conveyor	87" L x 102" W
Head Spacing	15" and 24"

Electrical Requirements	230/460 Vac. 3 phase 60hz
Strap Size	1/2" to 5/8"
Shipping weight	10,000 lbs.
Prewired 3 rd Head	Standard

Options:

Internal Turntable (Maximum Load 3000 lbs.)
Pallet Void Strap Feeders
System Control Capabilities
Spare Strapping Head and Test Stand
Head Lifting Device

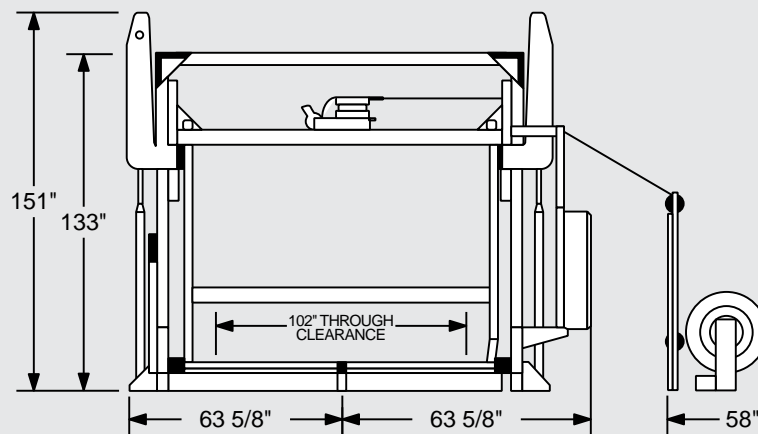

Centerline Conveyor

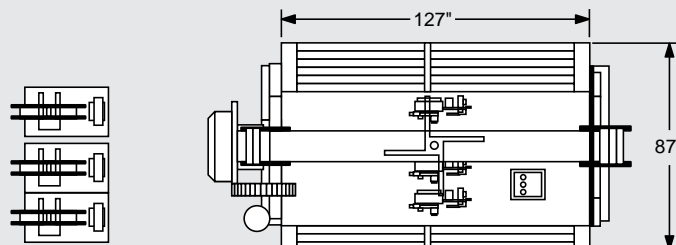

Samuel Strapping Systems

U.S.A.
1-800-323-4424
Canada
1-800-607-8727

www.samuelstrapping.com

SCU8.3.01/02